

Important – Please Read

Important - please read

Please read these instructions carefully before starting installation and keep for future reference.

Remove all packaging and check the product for missing parts or damage before starting installation.

Any alterations made to this product and fittings may infringe water regulations and will invalidate the guarantee.

The installation must comply with all Local/National Water Supply Authority Regulations/Byelaws and Building and Plumbing (UK:BS6700) Regulations.

We strongly recommend that you use a qualified and registered plumber.

General installation

These fittings are mixing devices and therefore water supplies must be reasonably balanced.

Where connections are made to the mains cold water supply, WRC approved single check valves must be fitted to both hot and cold inlets. This is a stated requirement of Water Supply (Water Fittings) Regulations 1999 Schedule 2, Section 15.

Before making any inlet pipe connections, all supply pipes MUST be thoroughly flushed to remove debris. Failure to do so could result in damage or low flow from the mixer unit. Water Supply (Water Fittings) Regulations 1999 Schedule 2, Section 13.

The fitting of isolating valves to the inlet feeds is advised for ease of maintenance.

Please take great care when installing this mixer not to damage its surface.

Please note if installing in an enclosed environment, access should be left for servicing and maintenance. No costs relating to inadequate access can be accepted.

Care of the mixer

Our products are finished to the highest standard and due care needs to be taken to ensure their looks are retained.

We recommend cleaning all products with a soft damp cloth ONLY and advise strongly against the use of ALL cleaning products i.e. powders and liquids.

If the above instructions are not followed this will invalidate your guarantee in the event of a problem occurring.

Operation

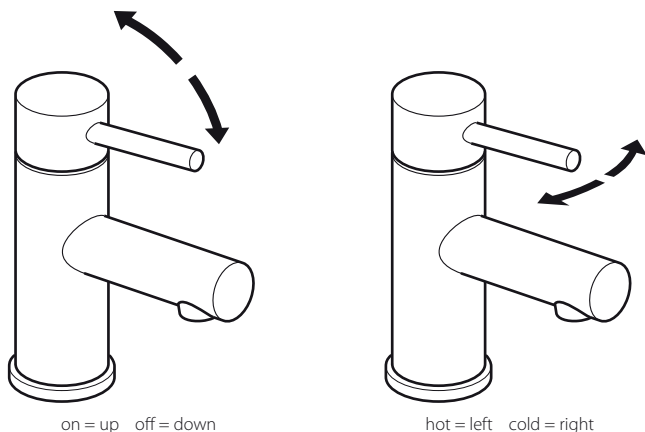

Moving the mixer lever upwards/downwards will increase/decrease the flow of water.

Moving the mixer lever from right to left will increase the water temperature.

Pull the vertical control rod up to close the waste outlet and push down to open.

Installation

Before installing your new mixer, flush through the pipework to ensure removal of debris, turn off the water supply.

Screw the two flexible pipes to the mixer body, tighten using the correct size spanner, but do not over tighten.

Screw the threaded rod into the back hole in the base of the mixer body.

Position the base ring onto the bottom of the mixer body (ensure the rubber 'O' ring is in place).

Position the mixer on the basin. From the underside of the basin fit the rubber washer onto the threaded rod followed by the metal washer and the nut. Tighten the nut to clamp the mixer to the basin.

CAUTION: Do not over tighten the nut as this may damage the basin.

Connect the water supply to the inlet pipes. The hot water should be connected to the left hand pipe.

