

IMPORTANT INFORMATION

- Thank you for purchasing this high quality Twin/Triple with Diverter Thermostatic Shower Valve. To ensure you get the very best use from this product, please read this installation guide thoroughly.
- These shower valves have separate controls for temperature & water flow control, and has been designed for concealed wall installations. The product is suitable for use on all plumbing systems including gravity, pumped, fully modulating combination boilers and unvented systems.
- Please make sure that any auxiliary products (e.g. shower kits) are suitable for connection to this product.
- Debris in the new pipe work can get into the cartridges. This is easily avoided by thoroughly flushing the pipe work **BEFORE** connecting the shower valve to the water supplies.
- This shower valve is suitable for use with all water supply systems up to a maximum dynamic water pressures of 5 bar (**balanced water pressures are desirable for best performance**). Pressures above this limit may require the fitting of pressure reducing valves into the incoming mains household water supply.
- This product must be installed in such a way as not to cause water damage during use. **We recommend that this product is fitted by a fully qualified installer. The installation must comply with all current water byelaws.**
- **NB. If you experience any difficulty with the installation or operation of your new shower valve, please refer to 'Fault Diagnosis' at the back of this guide.**

CLEANING & AFTER CARE

This product is made using high quality chrome plating, and this should be maintained using a clean damp cloth. No abrasive agents or materials should be used, and **any misuse will invalidate your guarantee.**

This precision made thermostatic shower valve will continue to give years of use provided it has been installed & operated in accordance with these fitting instructions. Failure to do this will invalidate any guarantees.

BOX CONTENTS

Please note: Handles & plate may vary depending on model supplied.

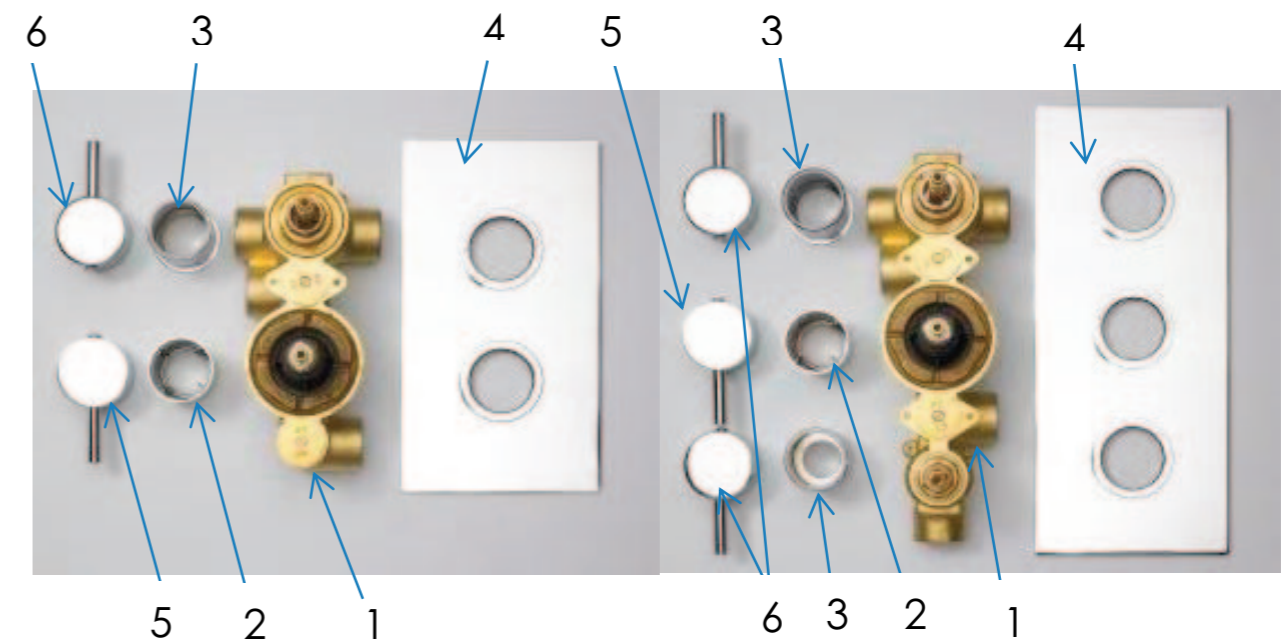

1. Main thermostatic shower valve body with diverter valve (and a CD valve for the triple body).
2. Chrome temperature body sleeve.
3. Chrome flow control sleeve.
4. Chrome concealing plate.
5. Chrome thermostatic control handle.
6. Chrome flow control handle.

PLUMBING CONNECTIONS:

Please note that the pipework on site running to the valve should be plumbed with the hot on the left and the cold on the right.

Twin Valve:

The hot inlet of the valve must be connected to the hot pipework. The hot inlet of the valve will be marked. When installed correctly the diverter valve will be at the top.

Triple Valve:

The hot inlet of the valve must be connected to the hot pipework. The hot inlet of the valve will be marked. When installed correctly the diverter valve will be at the top.

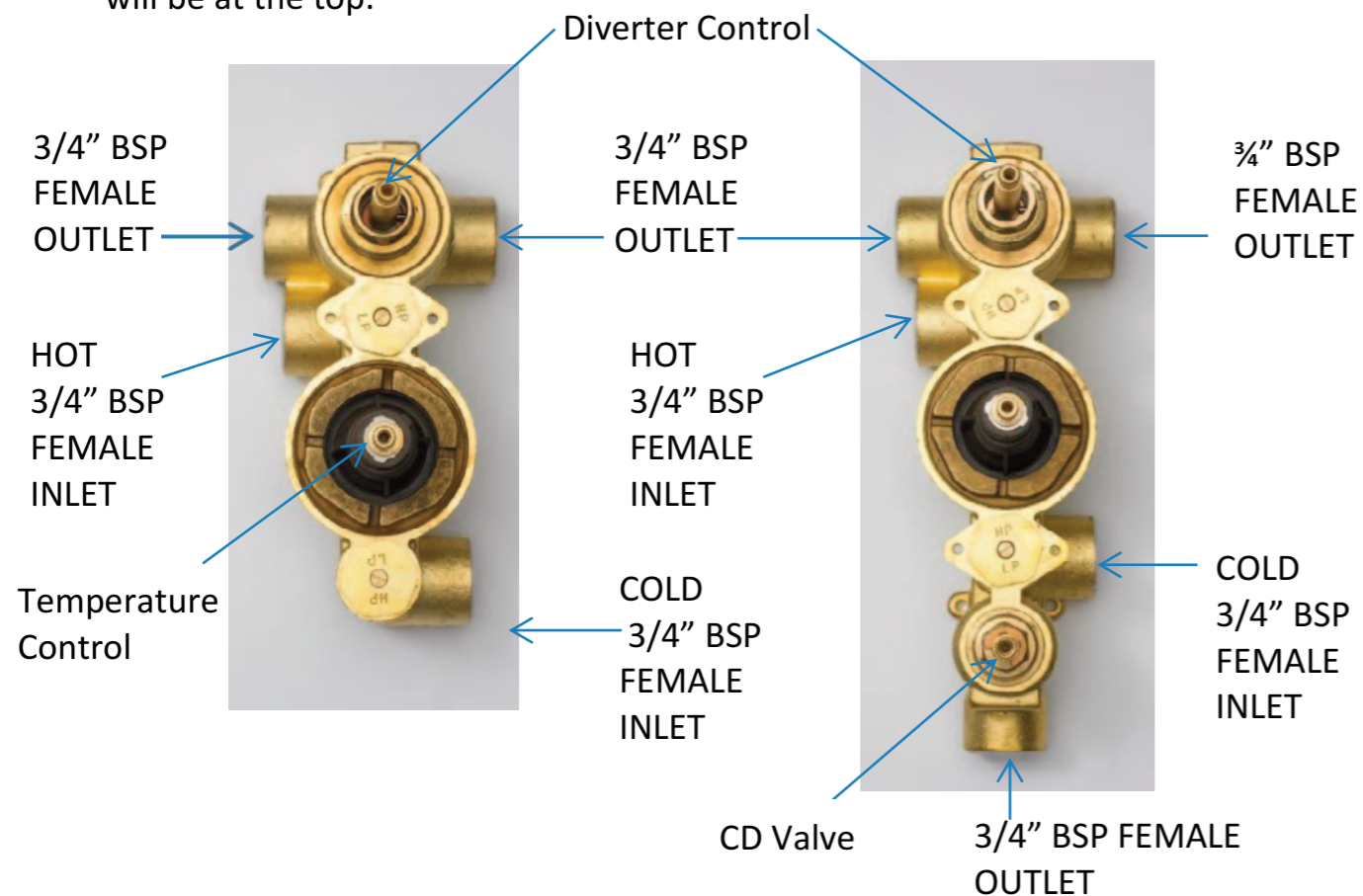

INSTALLATION

1. Before installation, please read the Conditions of Use section and ensure the supply system conditions comply.
2. Remove the chrome sleeves from the shower valve body, and leave to one side in a safe place.
3. You must install accessible isolation valves in the HOT & COLD water supply lines for servicing purposes. These valves have integral strainers in the inlets.
4. The plumbing connections on the inlets & outlet are all 3/4" BSP female threads.
5. Determine the fixing position for the valve and make a recess in the wall to house the valve. It should be from 72 to 85mm deep.
6. Using the screws provided, secure the shower valve body onto the wall, using the mounting lugs that are cast into the base of the body.
7. Now the shower valve body is securely mounted onto the wall, make sure the pipework is thoroughly flushed through to remove any debris from the system before connecting the water supplies. **Failure to do this could invalidate the guarantee.**
8. The plumbing connections should then be made to the HOT & COLD water inlets (which are clearly marked). **If for some reason the pipework feeds on site are the wrong way around, the cartridge can be taken out of the valve body, turned 180° and placed back in the valve body.**
9. Make the plumbing connection to the water outlet. This will take the water to the chosen auxiliary product (shower kit) you have selected to run with this shower.
10. Turn on the water supply and check for leaks.

11. Check the max water temperature from the terminal fitting with a thermometer. The recommended maximum terminal outlet temperature is 41°C. If the water temperature is not suitable please see the Temperature Adjustment Section. **Please Note: The mixed water temperature at the terminal fitting must never exceed 46°C.**
12. Re fit the chrome sleeves to the shower body.
13. Apply a small bead of silicone behind the chrome concealing plate (this will give a water tight seal so water cannot ingress into the wall cavity). Slide the plate into position over the chrome sleeves, and fit up against the finished wall surface.
14. Fit the chrome control handles. The thermostatic control handle is clearly marked with H & C.
15. Please see the Conditions of Use section.

TEMPERATURE ADJUSTMENT

1. Remove the handle on the thermostat control. The method will differ depending on the handle type. The spline/Brass Stop Ring will now be exposed.
2. If there is a Brass Stop Ring in place, please remove it. Turn the shower flow control fully on.
3. If the shower is too cold then turn the spline anti-clockwise. If the handle is too hot then turn the spline clockwise. Let the water temperature stabilise after every adjustment. We recommend a max temperature of 41°C. **The mixed water temperature at the terminal fitting must never exceed 46°C.**
4. When the temperature is correct turn the flow control off. Do not move the spline again until after the handle is secured in place. The max

temperature is now set and any movement of the spline will alter the temperature.

5. The handle can now be put back in place. **When the handle is being placed over the spline, please ensure that the handle Stop Lug is against the cartridge Stop Lug preventing the handle from being turned any further anticlockwise. This prevents the shower valve from reaching a temperature that is higher than the set point.** Depending on your handle type the temperature will be limited by a handle with an in build stop lug or by a separate Brass Stop Ring. Please see the diagrams below.
6. The handle can now be fixed in place. The shower should have a safe maximum showering temperature.

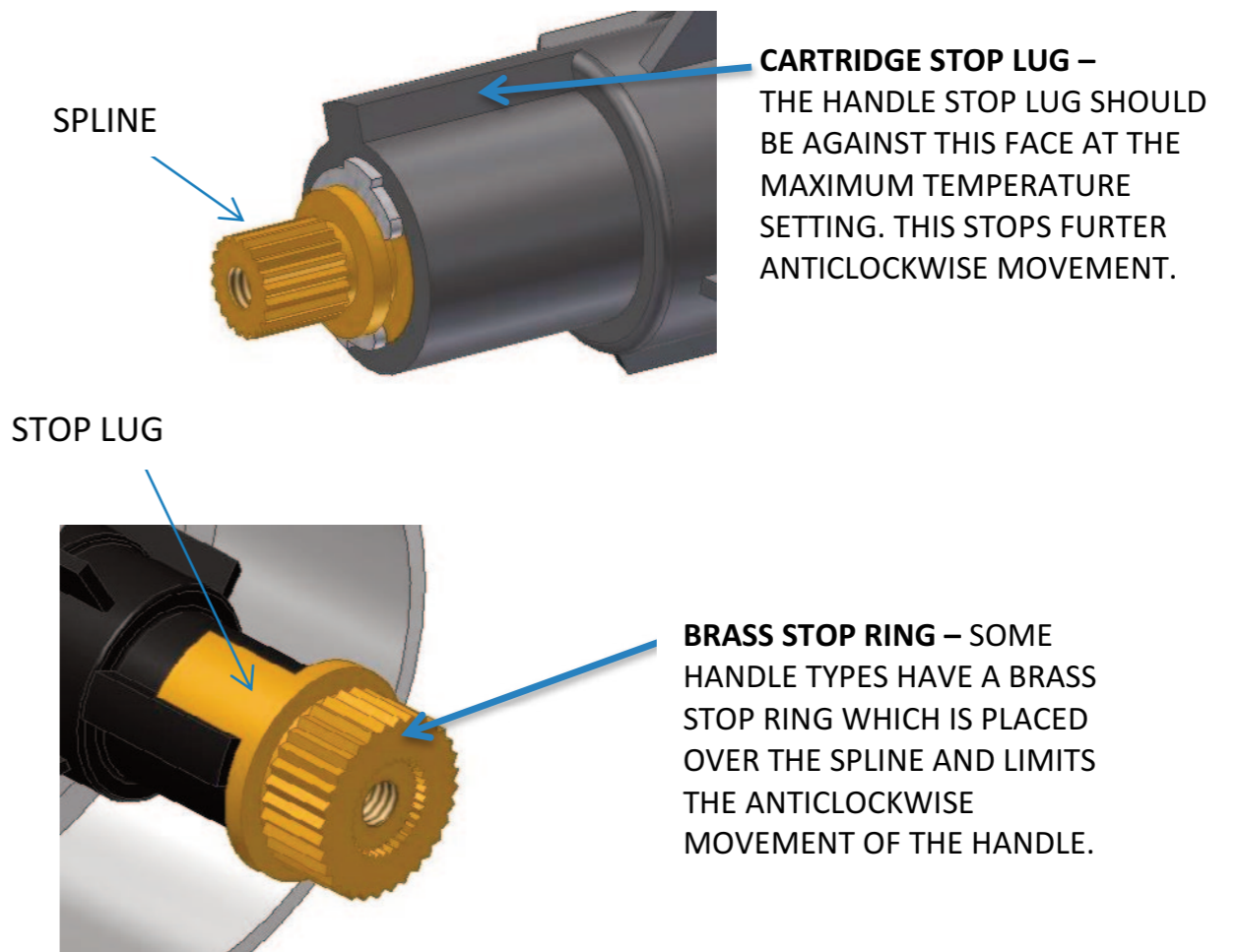

CONDITIONS OF USE

Conditions of use for Thermostatic Mixing Valves:

	High Pressure	Low Pressure
Maximum Static Pressure – Bar	10	10
Flow Pressure, Hot & Cold - Bar	0.5 to 5	0.1 to 1
Hot Supply Temperature - °C	55 to 65	55 to 65
Cold Supply Temperature - °C	Equal to or Less than 25°	Equal to or less than 25°

NOTE: Valves operating outside these conditions cannot be guaranteed to operate thermostatically.

Designation of use:

High Pressure Shower.

Low Pressure Shower.

If a water supply is fed by gravity then the supply pressure should be verified to ensure the conditions of use are appropriate for the valve.

Recommended outlet temperatures:

44°C for bath fill but see notes below;

41°C for showers;

41°C for washbasins;

38°C for bidets.

The mixed water temperatures must never exceed 46°C.

The maximum mixed water temperature can be 2°C above the recommended maximum set outlet temperatures.

NOTE:

Please Note: The mixed water temperature at the terminal fitting must never exceed 46°C. It is not a safe bathing temperature for adults or children. The British Burns Association recommends 37 to 37.5°C as a comfortable bathing temperature for children.

The thermostatic mixing valve will be installed in such a position that maintenance of the TMV and its valves and the commissioning and testing of the TMV can be undertaken.

The fitting of isolation valves is required as close as is practicable to the water supply inlets of the thermostatic mixing valve.

On Installation please make sure:

1. The supply pressures are within the valves operating range.
2. The supply temperatures are within the valves operating range.
3. Isolating valves (and strainers preferred) are provided.

If the operating conditions are within acceptable limits and the temperature has been set correctly, please carry out a cold water failure test by turning on the mixed water flow and then isolating the cold water supply to the Mixing Valve. After 5 seconds the mixed water flow should have stopped. If there is a residual flow, this is acceptable as long as the water temperature is within $\pm 2^\circ\text{C}$ of the initial temperature.

Please check the set temperature once a year and also carry out the cold supply isolation test outlined above.