

Important – Please Read

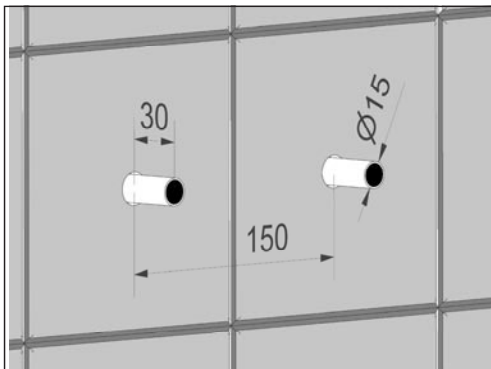

Ensure existing 15mm copper supply pipes are at 150mm centres and protrude from the tiling surface by 30mm.

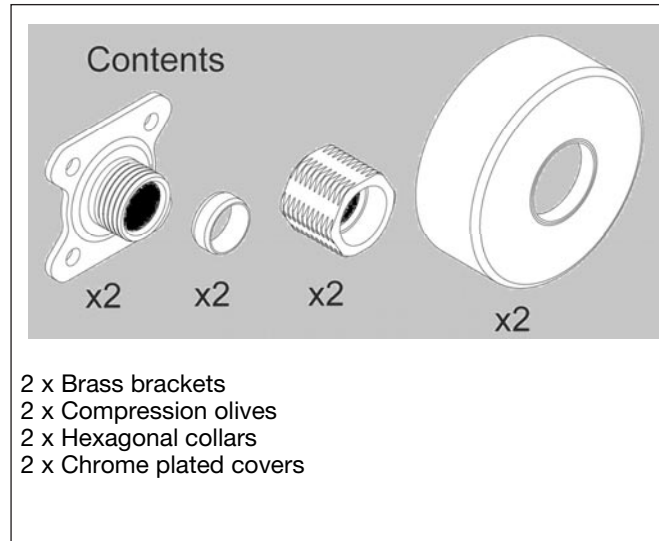
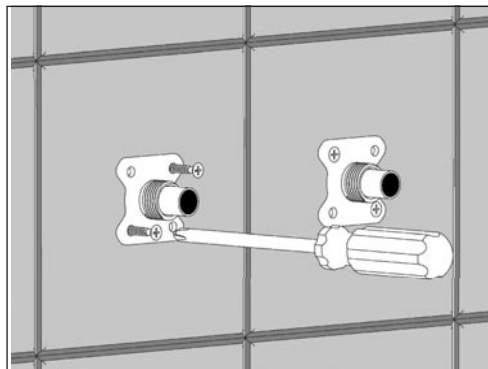

Offer up the brass brackets, ensure they are square and level, mark and then drill holes in the tiles or wall surface with a suitable drill. Insert wall plugs to suit the screws you have chosen (not supplied). Fix the brackets in place with at least two screws in each (preferably four in each).

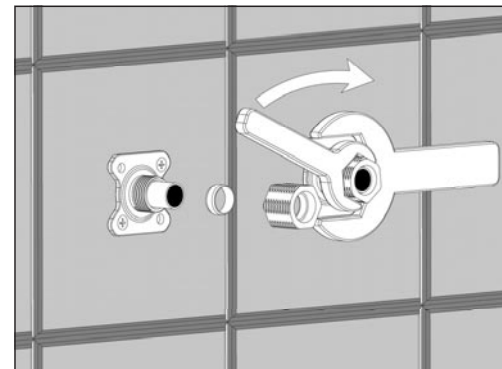

Slide the compression olive over the pipe and fit the hexagonal collar by tightening with a spanner. It is important that the brass bracket is supported by another spanner while tightening takes place.

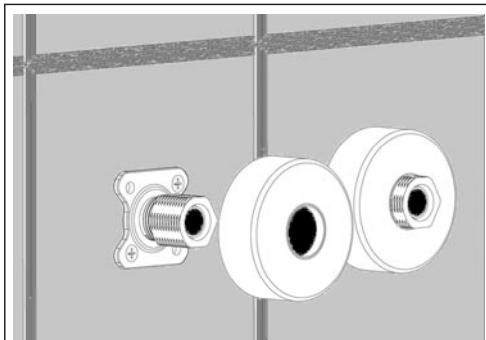

Spin the chrome plated covers on to the hexagonal collar and the connections are ready for the installation of the bar shower mixer.

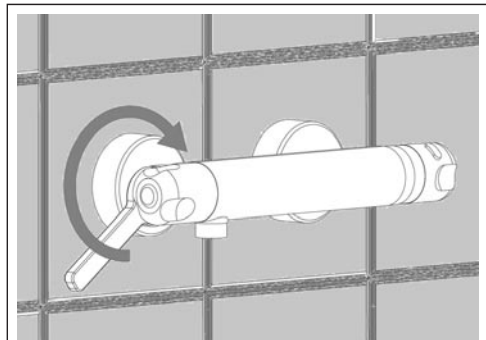

We recommend that the pipe work is well flushed through before installing the bar shower mixer to prevent debris damaging the mixer.