

150, 300 & 400 BASE UNITS

PLEASE READ. Carefully open the packs supplied and check the contents against the Fittings Checklist before discarding any packaging. To maintain the appearance of the units dust regularly with a soft cloth. For grime stains wipe with soft damp cloth using a mild detergent.

NOTE: Any additional components left after assembly may be required for installation-do not discard.

CAUTION: Some Fittings are small enough to choke a child.

1.		Wall Plate	2
2.		Hinge Plate	2
3.		Door Buffers	1
4.		Connecting Bolt	2
5.		12mm C/Sunk Screw	16
6.		Hinge	2
7.		Plinth Clip	2
8.		Leg Socket	4

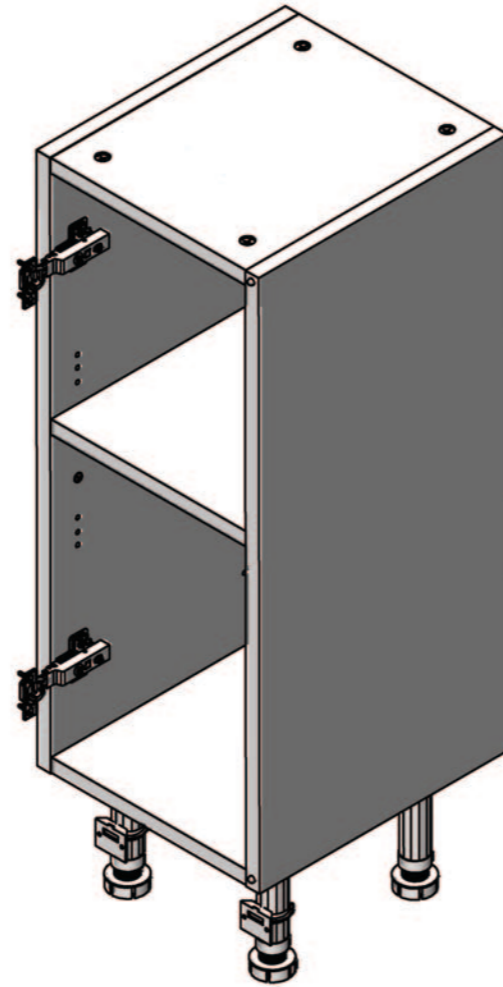

1. Attaching the Legs

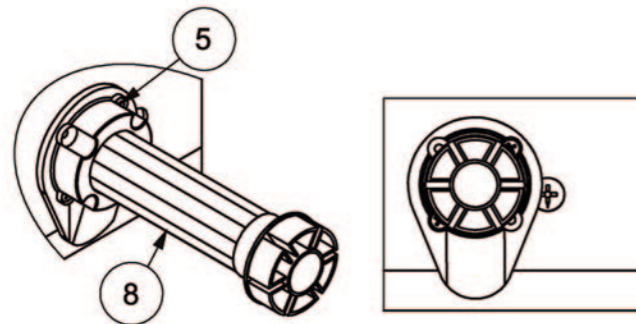

Insert the Leg Sockets (8) into the pre-drilled holes on the underside of the Bottom Panel. Ensure that the tab overlaps the End Panel. Fix using two screws (5) per socket and adjust the leg to suit a 150mm plinth. Use brackets (7) and screws (5) to secure the plinth to the legs. (See Step 4)

2. Positioning, Leveling & Fixing

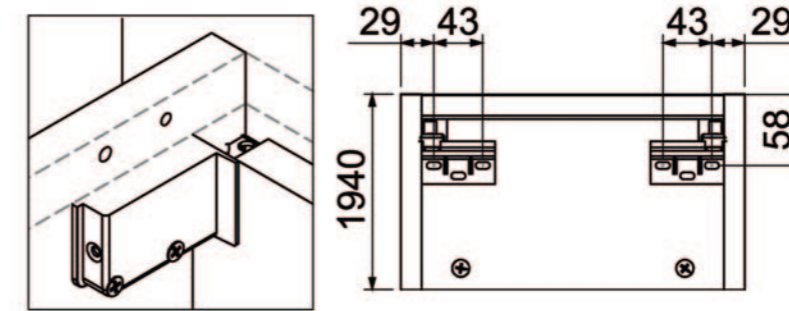

Fix Hanging plates (1) to the wall using suitable fixings (not supplied).

Level and join adjacent units by drilling through both cabinets with a 5mm drill bit and using connecting bolts (4).

3. Hinges & Hinge Adjustment (Note: Fascias supplied separately)

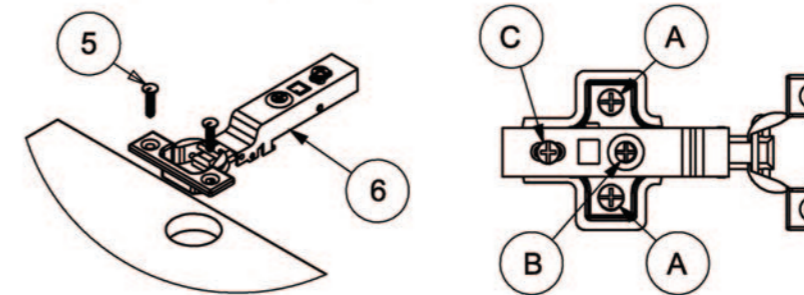

Adjustments apply when door is mounted.

A. Adjusts door Vertically.
B. Adjusts door horizontally.
C. Adjusts door in & out.

4. Plinth Attachment

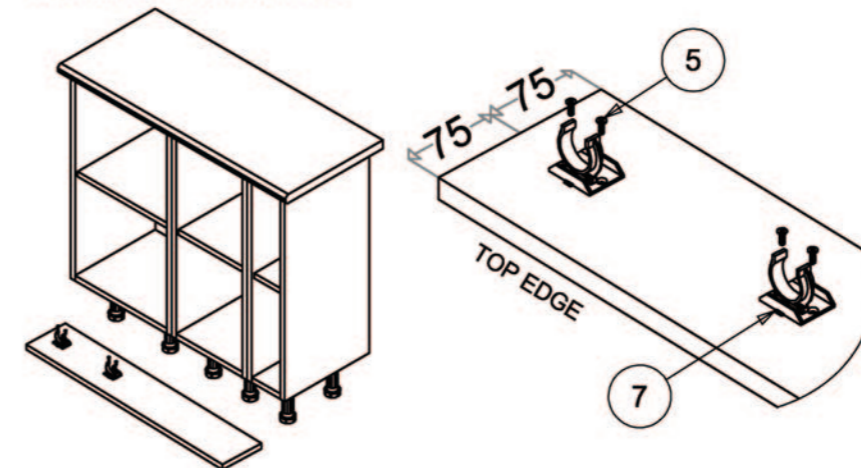

Position Plinth Mounting Brackets (7) 75mm from the top edge of the plinth and align length ways with the cabinet legs. Attach using screw (5).

5. Door Buffers

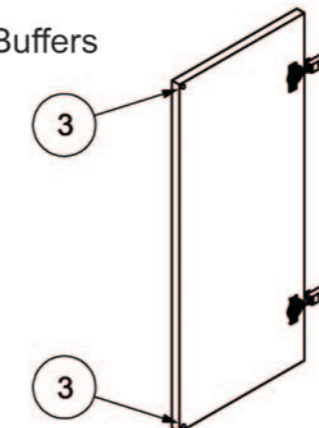

Position Door Buffers (3) at the top and bottom of each mounted door.